

IV18 VFD Clock assembling IV-18 tube board v.02

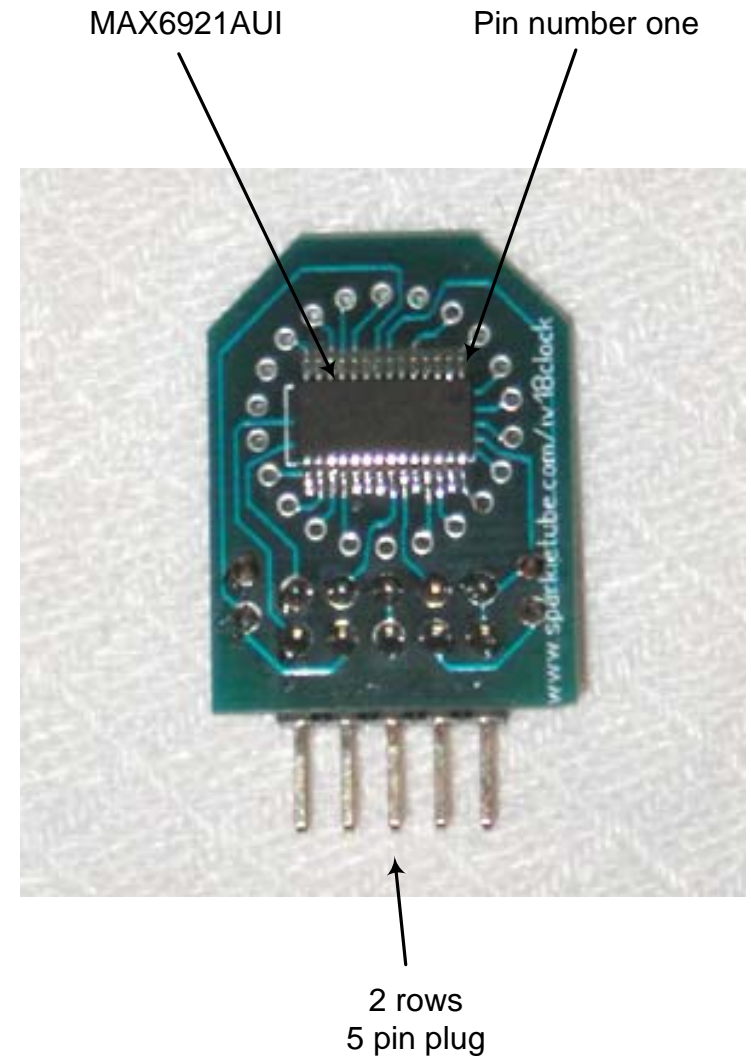
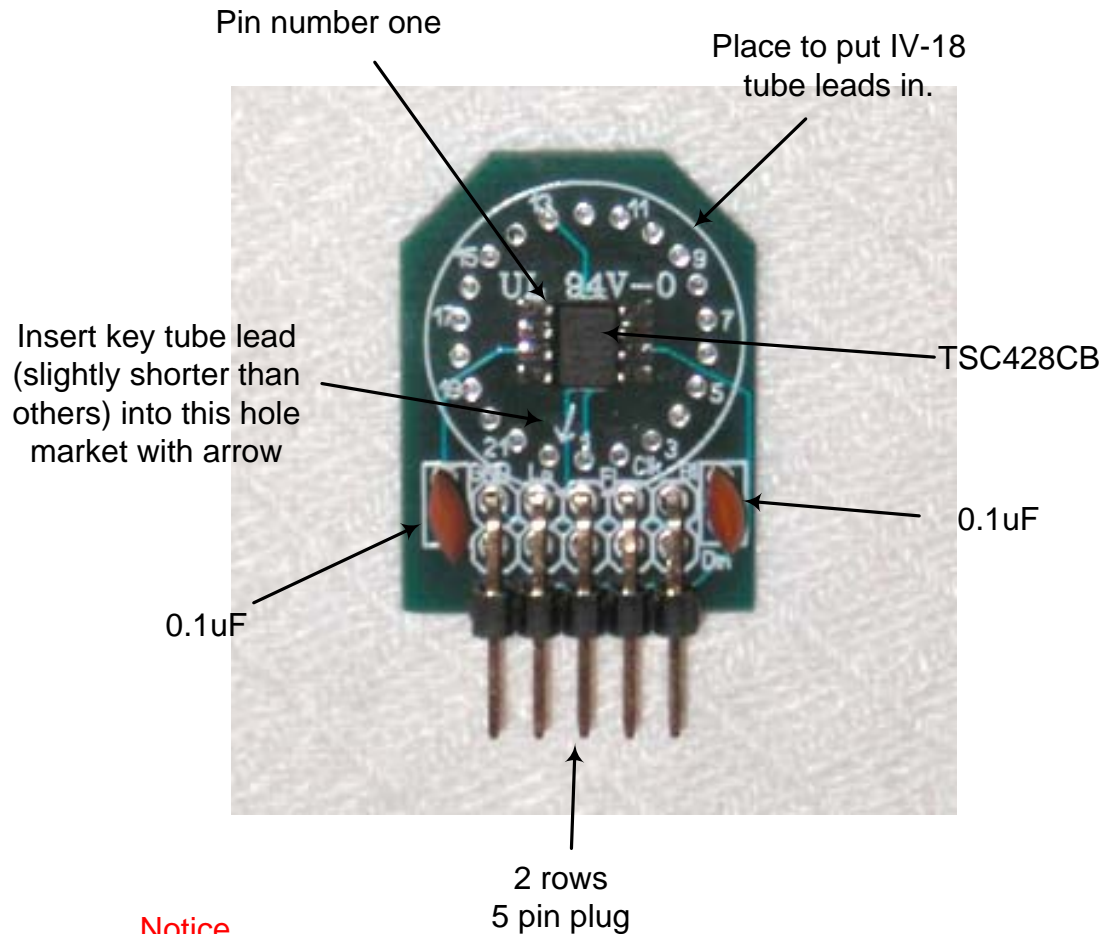

- Solder both SMD chips first. Double check you solder it properly
- On assembled PCB TSC428CB is covered by IV-18 tube, so it could be soldered/replaced only when IV-18 tube is out
- Insert key tube lead (slightly shorter than other) into the hole market with small arrow
- Use plenty of liquid flux to solder the MAX6921 and TSC428CB SMD chips
- Please find more recommendation in My Recommendation document